



# **MASTERBLOCK**

## **STANDARD C.M.U. PRODUCT GUIDE**

**2915 Waters Road Suite 105  
Eagan, Minnesota 55121  
Office: 651-683-0600**

**DISPATCH:**

**Twin Cities 952-423-2647  
Park Rapids 218-732-5688  
Fergus Falls 800-426-8162  
[www.aggregate-us.com](http://www.aggregate-us.com)**

# PLANT LOCATIONS

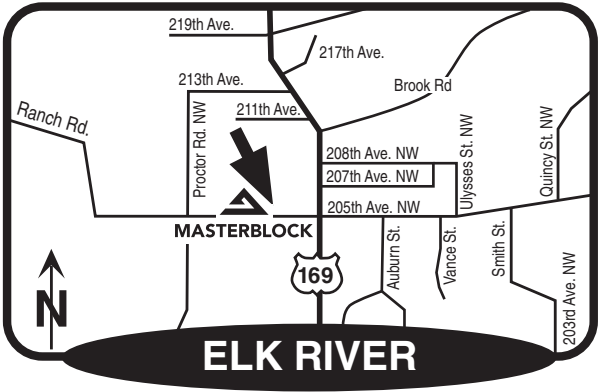

**11707 205th AVENUE**

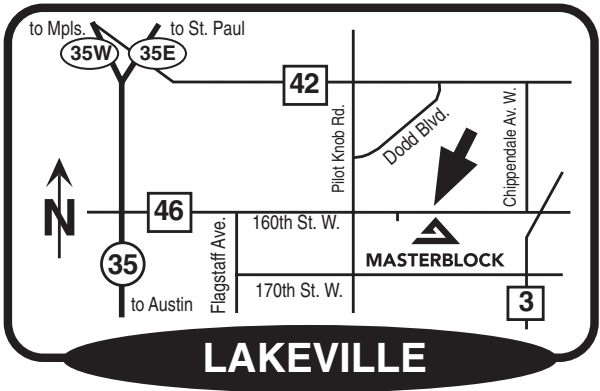

**5000 West 160th Street**

# PLANT LOCATIONS

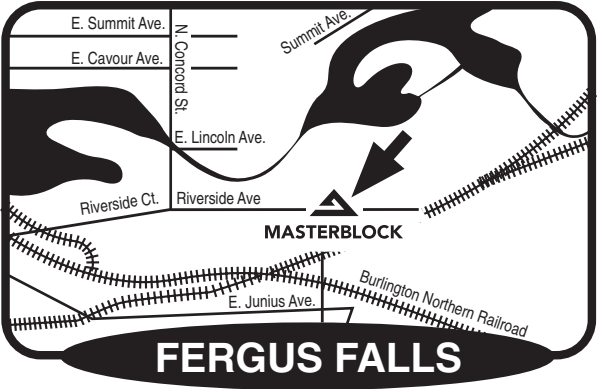

201 SOUTH PECK

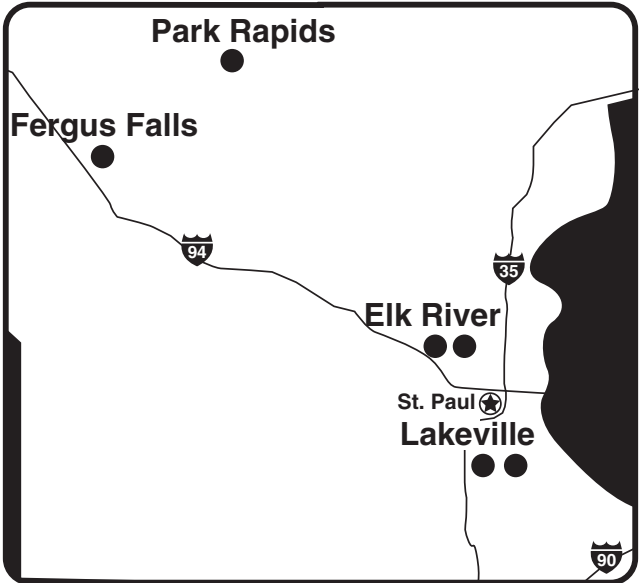

# TABLE OF CONTENTS

Technical Data #1.....	2
Technical Data #2.....	4
Technical Data #3.....	6
Delivery Data #1.....	8
Delivery Data #2.....	10
SolidBlock.....	12
DURABRICK.....	13
SillBlock.....	14
4 Inch Block.....	17
6 Inch Block.....	18
8 Inch Block.....	20
10 Inch Block.....	23
12 Inch Block.....	24
14 Inch Block.....	27
16 Inch Block.....	28
Scored Block.....	29
Soundblox® .....	30
Decorative Rock Face.....	32
Splyt Stone Quarry Series.....	35
Castle Rock.....	36
Shadow Stone.....	38
Split Face.....	40
Corduroy.....	42
BreakOff.....	43

# TECHNICAL DATA #1

## SPECIFICATIONS

All concrete masonry units manufactured by Masterblock:

- 1) exceed minimum standards as established by ASTM C90 for load bearing concrete masonry units.
- 2) meet all existing code requirements (Minnesota State Building Code is based on the International Building Code— I.B.C.)

All standard weight aggregate conforms to the requirements of ASTM C33.

All lightweight aggregate conforms to the requirements of ASTM C331.

## RATED FIRE RESISTIVE PERIODS

Fire resistance of concrete masonry units is determined by the "equivalent thickness" of the block and the type of aggregate. The equivalent thickness is the theoretical thickness of the block if all the concrete was molded into a solid unit. It is calculated by multiplying the actual thickness by the % of solids. As an example, an 8" block with 52% solids has an equivalent of 4.0 in. (7.625 x .52% = 4). The greater the equivalent thickness, the greater the fire rating.

Lightweight aggregate (expanded clay) has a better fire rating than standard weight aggregate (siliceous gravel). As an example, an 8" standard weight block has a 1 hour rating and an 8" lightweight block has a 2 hour rating. Filling the cores of the block with grout or other non-combustible material will increase the fire resistance. Applying plaster or gypsum wall board will also increase the fire resistance.

## Estimated Fire Resistive Periods of Walls and Partitions of Hollow Concrete Masonry Units

Minimum equivalent thickness for ratings of:			
Type of coarse aggregate:	4 hour	3 hour	2 hour
Expanded Clay (lightweight):	5.7"	4.9"	3.9"
Siliceous Gravel (standard weight):	6.2"	5.3"	4.2"
			1 hour
			2.7"
			2.8"

(Based on The International Building Code... as adopted by the Minnesota State Building Code)

## TECHNICAL DATA #1 continued

Wall Thickness	Block Number	Block Size (Inches)	Face Shell Thickness	Web Thickness	% Solid	Equivalent Thickness (Inches)	Fire Resistant Rating in Hours	
							Std. Wt.	Lt. Wt.
4"	0401002	4x8x16	1"	1"	75	2.7	-	1
4"	0401402	4x8x16	Solid	-	100	3.6	1	1
6"	0601224	6x8x16	1"	1"	57	3.2	1	1
6"	0601026	6x8x16	2"	1"	87	4.9	2	3
8"	0801000	8x8x16	1 1/4"	1"	52	4.0	1	2
8"	0801226	8x8x16	1 3/4"	1 1/4"	64	4.9	2	3
8"	0801227	8x8x16	2 1/2"	1 1/2"	77	5.9	3	4
8"	0801402	8x8x16	Solid	-	100	7.6	4	4
10"	1001000	10x8x16	1 3/8"	1 1/8"	51	4.9	2	3
*12"	1281000	12x8x16	1 1/4"	1 1/8"	45	5.2	2	3
12"	1201000	12x8x16	1 1/2"	1 1/8"	47	5.5	3	3
12"	1201028	12x8x16	2 1/8"	1 1/2"	57	6.6	4	4
14"	1401000	14x8x16	1 1/2"	1 1/8"	46	6.3	4	4
16"	1601000	16x8x16	1 1/2"	1 1/8"	44	6.9	4	4

\*NOTE: RESIDENTIAL

# TECHNICAL DATA #2

## THERMAL RESISTANCE VALUES (R-VALUES) FOR CONCRETE MASONRY WALLS

Calculated by the series-parallel method (required by the Minnesota Energy Code)

### STANDARD WEIGHT CONCRETE MASONRY UNITS: 132 POUNDS PER CUBIC FOOT DENSITY

DETAILS OF CONSTRUCTION	8"	10"	12"
(1) No Insulation	2.1	2.2	2.2
(2) Enerblock Continuous Polystyrene Inserts:			
(a) 4" Thickness	4.9	5.5	5.9
(b) 2 1/2" Thickness	4.6	5.0	5.2
(c) 2" Thickness	3.8	4.2	4.5
(d) 1 1/4" Thickness	3.7	4.0	4.1
(3) Cores filled with Polystyrene loose fill or Perlite loose fill	4.0	4.5	5.1
(4) Cores filled with Urea-Formaldehyde or Plastic Foam	4.0	4.7	5.2
(5) Added R-Value to any of the above walls:			
(a) Furring with 1 1/2" Molded Polystyrene and 1/2" Gypsum Board	5.5	5.5	5.5
(b) Furring with 1 1/2" Extruded Polystyrene and 1/2" Gypsum Board	6.5	6.5	6.5
(c) Furring with 1 1/2" Cellular Polyisocyanurate, Gas Impermeable Face and 1/2" Gypsum Board	7.6	7.6	7.6

## TECHNICAL DATA #2 continued

### LIGHTWEIGHT CONCRETE MASONRY UNITS: 95 POUNDS PER CUBIC FOOT DENSITY

DETAILS OF CONSTRUCTION	8"	10"	12"
(1) No Insulation	2.6	2.8	2.8
(2) Enerblock Continuous Polystyrene Inserts:			
(a) 4" Thickness	7.9	8.7	9.0
(b) 2 1/2" Thickness	7.1	7.5	7.7
(c) 2" Thickness	5.7	6.1	6.3
(d) 1 1/4" Thickness	5.3	5.6	5.7
(3) Cores filled with Polystyrene loose fill or Perlite loose fill	6.7	7.9	9.2
(4) Cores filled with Urea-Formaldehyde or Plastic Foam	7.1	8.4	9.7
(5) Added R-Value to any of the above walls:			
(a) Furring with 1 1/2" Molded Polystyrene and 1/2" Gypsum Board	5.5	5.5	5.5
(b) Furring with 1 1/2" Extruded Polystyrene and 1/2" Gypsum Board	6.5	6.5	6.5
(c) Furring with 1 1/2" Cellular Polyisocyanurate, Gas Impermeable Face and 1/2" Gypsum Board	7.6	7.6	7.6

1. For integrally insulated masonry, Series-parallel calculations are the method mandated by the U.S. Department of Energy, most State Energy Codes (including Minnesota and Wisconsin), the American Society of Heating, Refrigeration and Air-conditioning Engineers ASHRAE STANDARD 90.1 and the National Masonry Association (NCMA). The only acceptable alternative is testing according to the ASTM C-236 "Guarded Hot-Box" by an independent accredited laboratory at specific densities and properties.
2. Concrete thermal resistivity values (R per inch) are from NCMA TEK 6-2A, resistively high range (protected from moisture).  
Perlite loose fill thermal resistivity (R per inch) is taken from NCMA TEK 6-2A = 3.13; polystyrene loose fill is assumed the same as it is from various unknown scrap sources. Foam thermal resistivity values (R per inch) are from manufacturer's literature average of 3 companies = 4.46.
3. Enerblock R-values are from published "NCMA Concrete Masonry R-Value Evaluation" reports.
4. R-values include inside air film (.68) and outside air film (.17) co-efficients totalling R = .85.
5. All R-values are steady-state values to be used in the "ENVSTD" and "COMcheck" computer programs which allow for mass of walls; for other applications, a mass adjustment is allowed according to the 2000 International Energy Conservation Code Table 502.2.1.2(3).

# TECHNICAL DATA #3

## SOUND TRANSMISSION

### SOUND TRANSMISSION CLASS (STC) FOR SINGLE WYTHE CONCRETE MASONRY WALLS

WALL DESCRIPTION	4"	6"	8"	10"	12"
<b>No Surface Treatment:</b>					
hollow, standard weight	44	45	48	50	51
hollow, lightweight	41	43	45	47	49
solid, standard weight	45	48	54	55	56
<b>Surface Sealed with Paint:</b>					
both sides, hollow, standard weight	45	47	50	52	55
both sides, hollow, lightweight	42	45	47	49	51
<b>Surface Sealed with Plaster or Gypsum Board:</b>					
1/2" one side, hollow, standard weight	50	51	52	54	57
1/2" one side, hollow, lightweight	47	48	49	52	54

All STC ratings shown are calculated from test data and based on wall weights using standard and lightweight block as manufactured by Masterblock.

References:

- (1) National Concrete Masonry Association Tek Bulletin 13-2 (1997).
- (2) Minnesota Masonry Institute Cost Guide Book - 1991.

# TECHNICAL DATA #3 continued

## CORE FILLING DATA

Wall Thickness	Block Size (inches)	% Solid	Cu. Ft. of Material to Fill One Block	# of Block Per Cu. Yard
6"	6 x 8 x 16	57	.22	122
8"	8 x 8 x 16	52	.27	100
8"	8 x 8 x 16	64	.215	125
8"	8 x 8 x 16	77	.18	151
8"	8 x 8 x 16 BB	-	.23	118.5
10"	10 x 8 x 16	51	.325	83
12"	12 x 8 x 16	45	.47	57
12"	12 x 8 x 16	47	.46	59
12"	12 x 8 x 16	57	.37	73
12"	12 x 8 x 16 Lintel	-	.485	55.5
12"	12 x 8 x 16 BB	-	.42	64.5
14"	14 x 8 x 16	46	.50	54
16"	16 x 8 x 16	44	.61	44

# DELIVERY DATA #1

## SOLID CONCRETE MASONRY UNITS

Unit Size & Type	Unit Dry Weight	Units Per Cube	Weight Per Cube*	# Cubes 42,000 lb. Max. Load	Total # Of Blocks Per Load 42,000 lb.	# Cubes 50,000 lb. Max. Load**	Total # Of Blocks Per Load 50,000 lb.
2 x 8 x 16 Solid (SF or GS)	17	240	4130	10	2400	12	2880
3 x 8 x 16 Solid (SF or GS)	26.5	135	3628	11	1485	13	1755
3 x 8 x 16 Solid (RF)	28	135	3770	11	1485	13	1755
4 x 4 x 16 Solid (SF, GS or RF)	18	180	3240	12	2160	15	2700
4 x 8 x 16 Solid (SF or GS)	35	90	3200	13	1170	15	1350
4 x 8 x 16 Solid (RF)	36	90	3190	12	1080	15	1350
4 x 8 x 12 Solid (SF or GS)	26	120	3120	13	1560	16	1920
4 x 8 x 12 Solid (RF)	28	120	3410	12	1440	14	1680
4 x 12 x 12 Solid (SF, GS or RF)	38	72	2736	15	1080	18	1296
4 x 12 x 16 Solid (SF, GS or RF)	51	60	3180	13	780	15	900
4 x 12 x 16 Solid (SF, GS or RF)	53	70	3770	11	770	13	910
4 x 12 x 24 Solid (RF)	76	42	3252	12	504	14	588
4 x 16 x 24 Solid (RF)	102	35	3630	11	385	13	455

**CODE:** SF = Smooth Face  
 GS = Ground Stone  
 RF = Rock Face

\* Includes 50 lb. Pallet

\*\* Due to size and style of trucks and trailers, load weights may vary between 40,000 and 50,000 lbs.

## DELIVERY DATA #1 continued

Unit Size & Type	Unit Dry Weight	Units Per Cube	Weight Per Cube*	# Cubes 42,000 lb. Max. Load	Total # Of Blocks Per Load 42,000 lb.**	# Cubes 50,000 lb. Max. Load**	Total # Of Blocks Per Load 50,000 lb.
4 x 16 x 16 Solid (SF, GS or RF)	73	36	2628	15	540	19	684
6 x 4 x 16 Solid (SF, GS or RF)	26	120	3120	13	1560	16	1920
6 x 8 x 16 Solid (SF, GS or RF)	53	60	3180	13	780	15	900
8 x 8 x 16 Solid (SF or GS)	68	60	4130	10	600	11	660
8 x 8 x 16 Solid (RF)	71	45	3245	12	540	15	675
10 x 8 x 16 Solid (SF or GS)	85	36	3060	13	468	16	576
10 x 8 x 16 Solid (RF)	87	36	3132	13	468	15	540
12 x 8 x 16 Solid (SF or GS)	107	30	3210	13	390	15	450
12 x 8 x 16 Solid (RF)	109	30	3270	12	360	15	450

**CODE:**    **SF** = Smooth Face  
              **GS** = Ground Stone  
              **RF** = Rock Face

\* Includes 50 lb. Pallet

\*\* Due to size and style of trucks and trailers, load weights may vary between 40,000 and 50,000 lbs.

## DELIVERY DATA #2

## CORED CONCRETE MASONRY UNITS

Unit Size & Type	Unit Dry Weight	Units Per Cube	Weight Per Cube*	# Cubes 42,000 lb. Max. Load	Total # Of Blocks Per Load 42,000 lb.**	# Cubes 50,000 lb. Max. Load**	Total # Of Blocks Per Load 50,000 lb.
4 x 8 x 16 Cored Std. Wt. (SF or GS)	26	120	3170	13	1560	15	1800
4 x 8 x 16 Cored Std. Wt. (RF)	29	120	3530	11	1320	14	1680
4 x 8 x 16 Cored LW (SF or GS)	20	150	3000	14	2100	16	2400
6 x 8 x 16 Cored Std. Wt. (SF or GS)	29.5	100	3000	14	1200	16	1600
6 x 8 x 16 Std. Wt. (RF)	34	80	2720	15	1200	18	1440
6 x 8 x 16 Cored LW (SF or GS)	23	120	2810	15	1800	17	2040
8 x 8 x 16 Cored Std. Wt. (SF or GS)	37	75	2826	15	1125	17	1275
8 x 8 x 16 Cored Std. Wt. (RF)	43	75	3275	12	900	15	1125
8 x 8 x 16 Cored LW (SF or GS)	28	90	2570	16	1440	18	1620
8 x 8 x 16 Bond Beam Std. Wt. (SF or GS)	49	75	3725	11	825	13	975
8 x 8 x 16 Bond Beam Std. Wt. (RF)	57	75	4325	9	675	11	825
8 x 8 x 16 Bond Beam LW (SF or GS)	37.5	90	3425	12	1080	14	1260
10 x 8 x 16 Cored Std. Wt. (SF or GS)	48	65	3170	13	845	15	975
10 x 8 x 16 Cored Std. Wt. (RF)	52	60	3120	13	780	16	960

**CODE:** SF = Smooth Face  
GS = Ground Stone  
RF = Rock Face  
LW = Lightweight

\* Includes 50 lb. Pallet

\*\* Due to size and style of trucks and trailers, load weights may vary between 40,000 and 50,000 lbs.

## DELIVERY DATA #2 continued

Unit Size & Type	Unit Dry Weight	Units Per Cube	Weight Per Cube*	# Cubes 42,000 lb. Max. Load	Total # Of Blocks Per Load 42,000 lb.**	# Cubes 50,000 lb. Max. Load**	Total # Of Blocks Per Load 50,000 lb.
10 x 8 x 16 Bond Beam Std. Wt. (SF or GS)	60	65	3950	10	650	12	780
10 x 8 x 16 Bond Beam Std. Wt. (RF)	77	60	4620	9	540	10	600
10 x 8 x 16 Bond Beam LW (SF or GS)	52	65	2860	14	770	17	935
12 x 8 x 16 Cored Std. Wt. (SF) Reg Cure	51	55	2855	14	770	17	935
12 x 8 x 16 Cored Std. Wt. (SF or GS) Type I	50	50	2550	16	800	18	900
12 x 8 x 16 Cored Std. Wt. (RF)	56	50	2850	14	700	17	850
12 x 8 x 16 Cored LW (SF or GS)	39	60	2390	16	960	18	1080
12 x 8 x 16 Bond Beam Std. Wt. (SF or GS)	74	50	3700	11	550	13	650
12 x 8 x 16 Bond Beam Std. Wt. (RF)	84	50	4250	9	450	11	550
12 x 8 x 16 Bond Beam LW (SF or GS)	50	60	3060	13	780	16	960
14 x 8 x 16 Cored Std. Wt. (SF or GS)	58	45	2660	15	675	18	810
14 x 8 x 16 Cored LW (SF or GS)	43	45	1985	16	720	18	810
16 x 8 x 16 Cored Std. Wt. (SF)	62	45	2840	14	630	17	765
16 x 8 x 16 Cored Std. Wt. (SF or GS)	61	45	2795	15	675	17	765
16 x 8 x 16 Cored Std. Wt. (RF)	63	30	1940	16	480	18	540
16 x 8 x 16 Cored LW (SF or GS)	46	30	1400	16	480	18	540

### CODE:

**SF** = Smooth Face  
**GS** = Ground Stone  
**RF** = Rock Face  
**LW** = Lightweight

\* Includes 50 lb. Pallet

\*\* Due to size and style of trucks and trailers, load weights may vary between 40,000 and 50,000 lbs.



**MASTERBLOCK**

# SOLID BLOCK



BRICK  
0201400

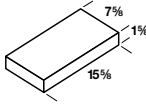

SOLID  
0201402

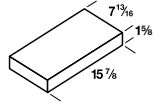

PATIO SOLID  
0201401

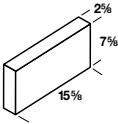

SOLID  
0301402

\*

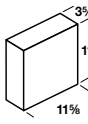

SOLID  
1241476

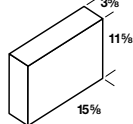

SOLID  
1241402

\*

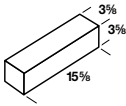

SOLID  
0441402

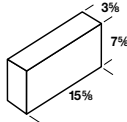

SOLID  
0401402

\*

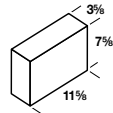

SOLID  
0401476

\*

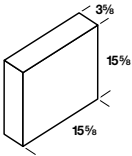

SOLID  
1641402

\*

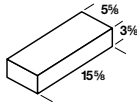

SOLID  
0641402

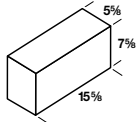

SOLID  
0601402

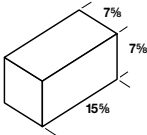

SOLID  
0801402

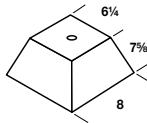

TAPERED PIER  
0801495

\*

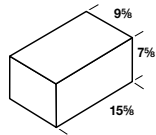

SOLID  
1001402

\* Special Order - Units may be subject to short run charges and minimum order requirements.

# SOLID BLOCK



\*

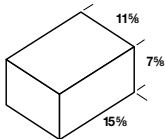

SOLID  
1201402

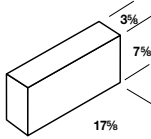

SOLID  
0401842

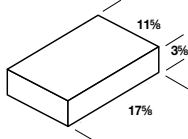

SOLID  
1241842

\* Special Order - Units may be subject to short run charges and minimum order requirements.



# DURABRICK

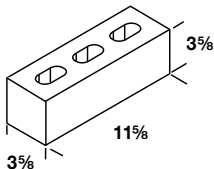

0441900

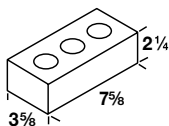

0421900

# SILL BLOCK

For sills not pictured, contact customer service

\*

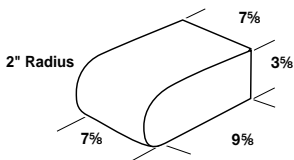

**1041349021**

\*

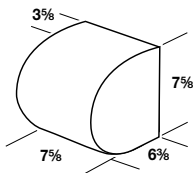

**0601384021**

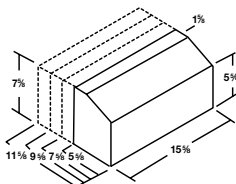

**0601362020**  $5 \frac{5}{8} \times 7 \frac{5}{8} \times 15 \frac{5}{8}$   
**0801364020**  $7 \frac{5}{8} \times 7 \frac{5}{8} \times 15 \frac{5}{8}$   
**1001366020**  $9 \frac{5}{8} \times 7 \frac{5}{8} \times 15 \frac{5}{8}$   
**1201368020**  $11 \frac{5}{8} \times 7 \frac{5}{8} \times 15 \frac{5}{8}$

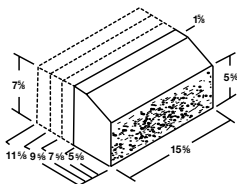

**0601362022**  $7 \frac{5}{8} \times 7 \frac{5}{8} \times 15 \frac{5}{8}$   
**0801364022**  $7 \frac{5}{8} \times 7 \frac{5}{8} \times 15 \frac{5}{8}$   
**1001366022**  $9 \frac{5}{8} \times 7 \frac{5}{8} \times 15 \frac{5}{8}$   
**1201368022**  $11 \frac{5}{8} \times 7 \frac{5}{8} \times 15 \frac{5}{8}$

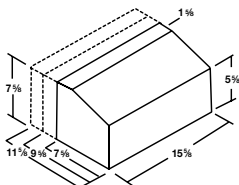

**0801362020**  $7 \frac{5}{8} \times 7 \frac{5}{8} \times 15 \frac{5}{8}$   
**1001364020**  $9 \frac{5}{8} \times 7 \frac{5}{8} \times 15 \frac{5}{8}$   
**1201366020**  $11 \frac{5}{8} \times 7 \frac{5}{8} \times 15 \frac{5}{8}$

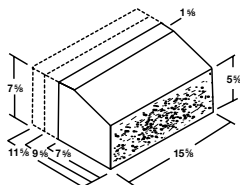

**0801362022**  $7 \frac{5}{8} \times 7 \frac{5}{8} \times 15 \frac{5}{8}$   
**1001364022**  $9 \frac{5}{8} \times 7 \frac{5}{8} \times 15 \frac{5}{8}$   
**1201366022**  $11 \frac{5}{8} \times 7 \frac{5}{8} \times 15 \frac{5}{8}$

\* Special Order - Units may be subject to short run charges and minimum order requirements.

# SILL BLOCK

For sills not pictured, contact customer service

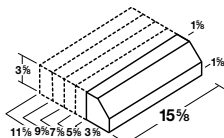

- 0441322020** 3 5/8 x 3 5/8 x 15 5/8
- 0641324020** 5 5/8 x 3 5/8 x 15 5/8
- 0841326020** 7 5/8 x 3 5/8 x 15 5/8
- 1041328020** 9 5/8 x 3 5/8 x 15 5/8
- 1241320020** 11 5/8 x 3 5/8 x 15 5/8

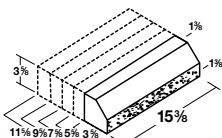

- 0441322022** 3 5/8 x 3 5/8 x 15 5/8
- 0641324022** 5 5/8 x 3 5/8 x 15 5/8
- 0841326022** 7 5/8 x 3 5/8 x 15 5/8
- 1041328022** 9 5/8 x 3 5/8 x 15 5/8
- 1241320022** 11 5/8 x 3 5/8 x 15 5/8

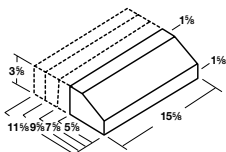

- 0641322020** 5 5/8 x 3 5/8 x 15 5/8
- 0841324020** 7 5/8 x 3 5/8 x 15 5/8
- 1041326020** 9 5/8 x 3 5/8 x 15 5/8
- 1241328020** 11 5/8 x 3 5/8 x 15 5/8

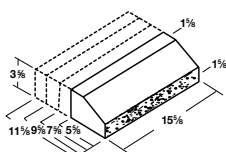

- 0641322022** 5 5/8 x 3 5/8 x 15 5/8
- 0841324022** 7 5/8 x 3 5/8 x 15 5/8
- 1041326022** 9 5/8 x 3 5/8 x 15 5/8
- 1241328022** 11 5/8 x 3 5/8 x 15 5/8



**MASTERBLOCK**

# SILL BLOCK

For sills not pictured, contact customer service

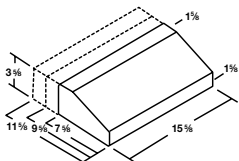

- 0841322020** 7 5/8 x 3 5/8 x 15 5/8
- 1041324020** 9 5/8 x 3 5/8 x 15 5/8
- 1241326020** 11 5/8 x 3 5/8 x 15 5/8

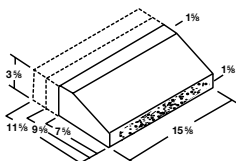

- 0841322022** 7 5/8 x 3 5/8 x 15 5/8
- 1041324022** 9 5/8 x 3 5/8 x 15 5/8
- 1241326022** 11 5/8 x 3 5/8 x 15 5/8

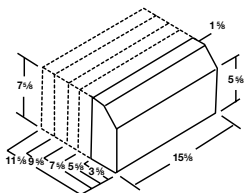

- 0401362020** 3 5/8 x 7 5/8 x 15 5/8
- 0601364020** 5 5/8 x 7 5/8 x 15 5/8
- 0801366020** 7 5/8 x 7 5/8 x 15 5/8
- 1001368020** 9 5/8 x 7 5/8 x 15 5/8
- 1201360020** 11 5/8 x 7 5/8 x 15 5/8

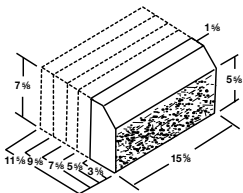

- 0401362022** 3 5/8 x 7 5/8 x 15 5/8
- 0601364022** 5 5/8 x 7 5/8 x 15 5/8
- 0801366022** 7 5/8 x 7 5/8 x 15 5/8
- 1001368022** 9 5/8 x 7 5/8 x 15 5/8
- 1201360022** 11 5/8 x 7 5/8 x 15 5/8

# 4 " BLOCK

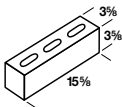

HALF HIGH  
0441002

\*

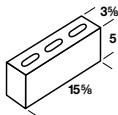

STARTER  
0451002

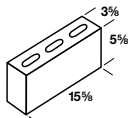

STARTER  
0461002

8

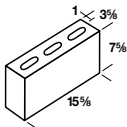

DOUBLE END  
(ALSO AVAILABLE IN 2 CORE)  
0401002

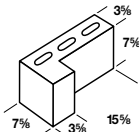

L - CORNER  
0401003

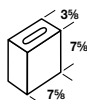

HALF LENGTH  
0401005

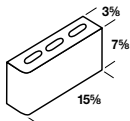

SINGLE BULL NOSE  
0401006



HALF SINGLE BULL NOSE  
0401007

\*

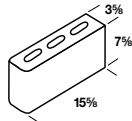

DOUBLE BULL NOSE END  
0401010

\*



HALF DOUBLE  
BULL NOSE END  
0401011

\*

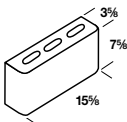

DOUBLE BULL NOSE FACE  
0401012

\*

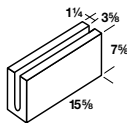

BOND BEAM  
0401072

NOTE: Not available in Ground Stone

8

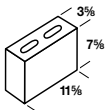

3/4 LENGTH  
0401076

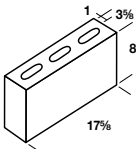

FULL HIGH DOUBLE END  
0481802

\* Special Order - Units may be subject to short run charges and minimum order requirements.

8 Full 8" high available.

Bull Nose= 1" Radius



**MASTERBLOCK**

# 6" BLOCK

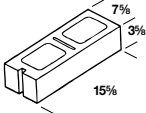

HALF HIGH  
DOUBLE END W/SASH  
0641224

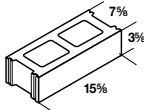

HALF HIGH  
PLAIN  
0641224

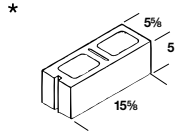

STARTER  
0651224

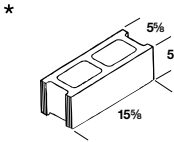

STARTER  
0651224

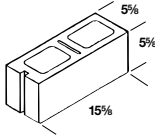

STARTER  
0661224

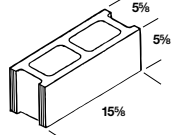

STARTER  
0661224

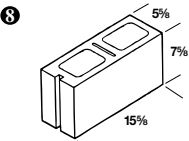

DOUBLE END W/SASH  
0601224

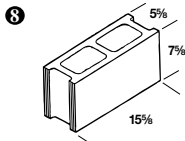

PLAIN  
0601224

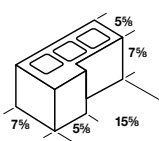

L-CORNER  
0601003



HALF LENGTH  
0601005

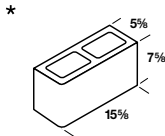

SINGLE BULL NOSE  
0601006

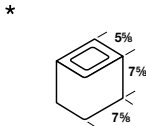

HALF SINGLE BULL NOSE  
0601007

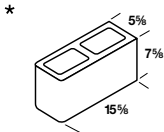

DOUBLE BULL NOSE END  
(2 OR 3 CORE)  
0601010

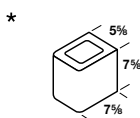

HALF DOUBLE  
BULL NOSE END  
0601011

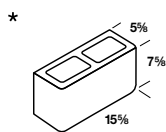

DOUBLE BULL NOSE FACE  
0601012

\* Special Order - Units may be subject to short run charges and minimum order requirements.

8 Full 8" high available.

Bull Nose= 1" Radius

# 6" BLOCK

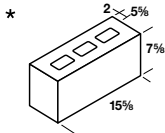

87% SOLID  
0601026

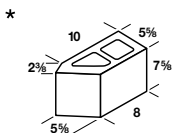

45° ANGLE CORNER  
0601052

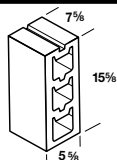

HIGH LINTEL (KNOCK OUT)  
0601064

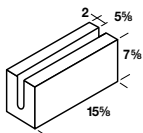

BOND BEAM  
0601072

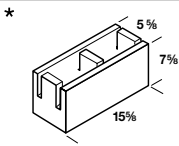

FLOW THRU BOND BEAM  
0601073

★ Special Order - Units may be subject to short run charges and minimum order requirements.



**MASTERBLOCK**

# 8" BLOCK

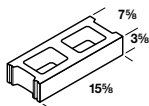

HALF HIGH PLAIN  
0841224

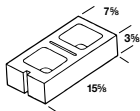

HALF HIGH DOUBLE END  
W/SASH  
0841224

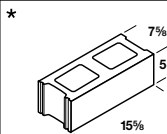

STARTER  
0851224

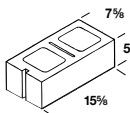

STARTER  
0851224

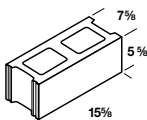

STARTER  
0861224

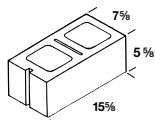

STARTER  
0861224

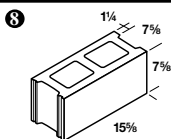

PLAIN  
(3 CORE SPECIAL ORDER)  
0801000

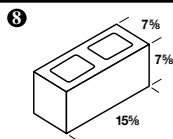

DOUBLE END  
2 OR 3 CORE  
0801002

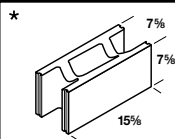

ENERBLOCK  
(MADE FOR ENERBLOCK INSERT)  
0801121

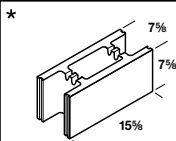

FORM BLOCK  
0801131

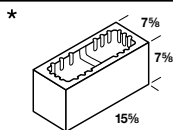

FORM BLOCK  
ALL PURPOSE CORNER  
0801132

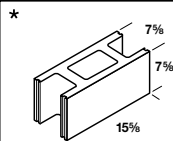

OPEN CORE  
0801001

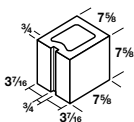

HALF SASH  
0801004

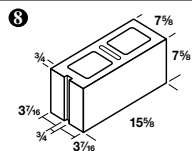

DOUBLE END WITH SASH  
0801224

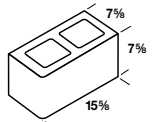

SINGLE BULL NOSE  
0801006

\* Special Order - Units may be subject to short run charges and minimum order requirements.

8 Full 8" high available.

# 8" BLOCK

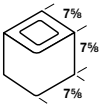
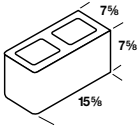
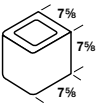
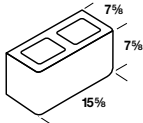
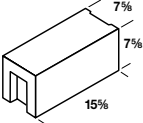
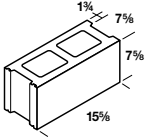
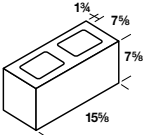
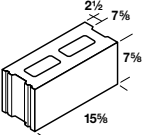
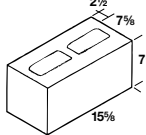
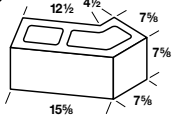
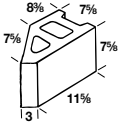
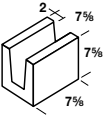
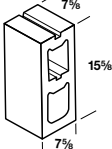
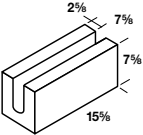
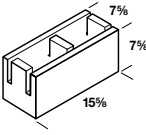

 <p>HALF SINGLE BULL NOSE 0801007</p>	<p>*</p>  <p>DOUBLE BULL NOSE END 0801010</p>	<p>*</p>  <p>HALF DOUBLE BULL NOSE 0801011</p>
<p>*</p>  <p>DOUBLE BULL NOSE FACE 0801012</p>	<p>8</p>  <p>FILLED TOP 0801025</p>	 <p>64% SOLID 0801226</p>
 <p>64% SOLID 0801226</p>	 <p>77% SOLID 0801227</p>	 <p>77% SOLID 0801227</p>
<p>*</p>  <p>45° EXTENDED ANGLE CORNER 0801051</p>	<p>8</p>  <p>45° ANGLE CORNER 0801052</p>	<p>*</p>  <p>HALF LINTEL 0801061</p>
 <p>HIGH LINTEL (KNOCK OUT) 0801064</p>	 <p>BOND BEAM 0801072</p>	 <p>FLOW THRU BOND BEAM (KNOCK OUT) 0801073</p>

\* Special Order - Units may be subject to short run charges and minimum order requirements.

8 Full 8" high available.

Bull Nose = 1" Radius.



**MASTERBLOCK**

# 8" BLOCK

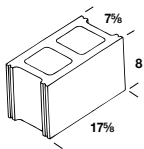

FULL HIGH PLAIN  
0881800

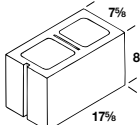

FULL HIGH DOUBLE END  
W/SASH  
0881824

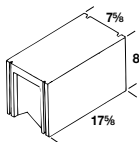

FULL HIGH FILLED TOP  
0881825

# 10" BLOCK



8

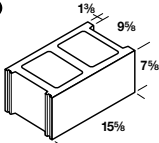

PLAIN  
1001000

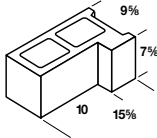

L-CORNER  
1001003

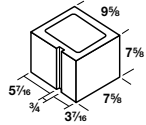

HALF SASH  
1001004

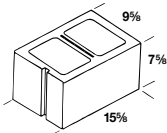

DOUBLE END W/SASH  
1001024

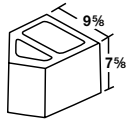

45 DEGREE CORNER  
1001052

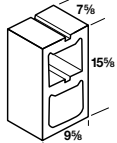

HIGH LINTEL  
(KNOCK OUT)  
1001064

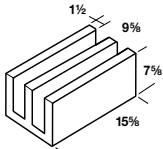

BOND BEAM  
1001072

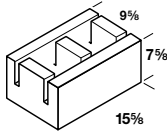

FLOW THRU BOND BEAM  
(KNOCK OUT)  
1001073

8 Full 8" high available.



**MASTERBLOCK**

# 12" BLOCK

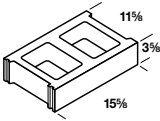

HALF HIGH PLAIN  
1241224

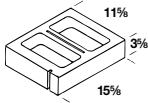

HALF HIGH DOUBLE END  
W/SASH  
1241224

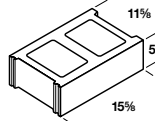

STARTER  
1251220

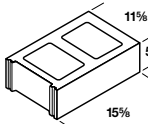

STARTER SINGLE END  
1251220

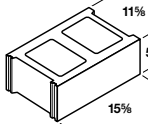

STARTER  
1261220

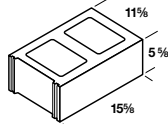

STARTER SINGLE END  
1261220

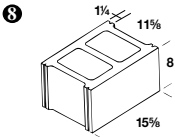

PLAIN RESIDENTIAL  
1281000

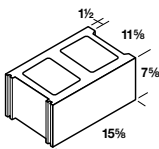

PLAIN COMMERCIAL  
1201000

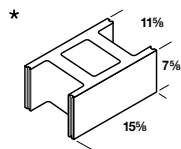

OPEN CORE  
1201001

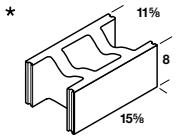

ENERBLOCK  
(MADE FOR ENERBLOCK INSERT)  
1201121

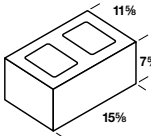

DOUBLE END  
1201002

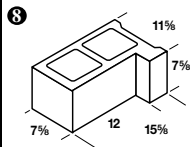

L-CORNER  
1201003

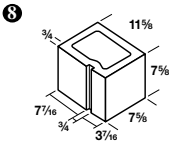

HALF SASH  
1201004

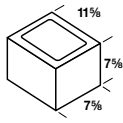

HALF LENGTH  
1201005

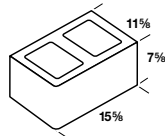

SINGLE BULL NOSE  
1201006

\* Special Order - Units may be subject to short run charges and minimum order requirements.

⑧ Full 8" high available.

Bull Nose = 1" Radius.

# 12" BLOCK

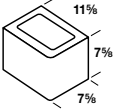
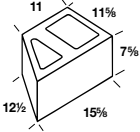
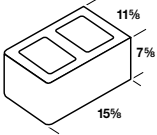
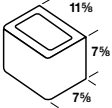
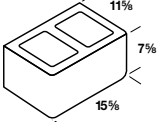
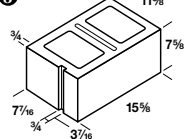
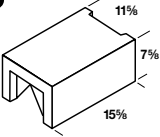
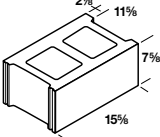
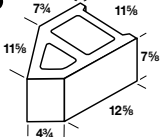
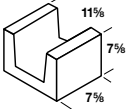
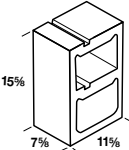
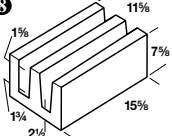
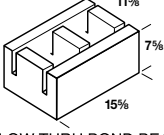
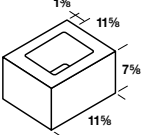
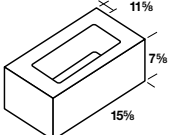

 <p>11% 7% 7%</p> <p>HALF SINGLE BULL NOSE 1201007</p>	<p>*</p>  <p>11 11% 7% 12½ 15%</p> <p>22 1/2° MITERED 1201048</p>	<p>*</p>  <p>11% 7% 15%</p> <p>DOUBLE BULL NOSE END 1201010</p>
<p>*</p>  <p>11% 7% 7%</p> <p>HALF DOUBLE BULL NOSE END 1201011</p>	<p>*</p>  <p>11% 7% 15%</p> <p>DOUBLE BULL NOSE FACE 1201012</p>	<p>8</p>  <p>11% 7% 15% ¾ 7/16 ¾ 3/16</p> <p>DOUBLE END W/SASH 1201024</p>
<p>8</p>  <p>11% 7% 15%</p> <p>FILLED TOP 1201025</p>	<p>*</p>  <p>2½ 11% 7% 15%</p> <p>57% SOLID 1201028</p>	<p>8</p>  <p>11% 7% 7% 11% 12% 4% ¾</p> <p>45° ANGLE CORNER 1201052</p>
<p>*</p>  <p>11% 7% 7%</p> <p>HALF LINTEL 1201061</p>	 <p>15% 7% 11%</p> <p>HIGH LINTEL (KNOCK OUT) 1201064</p>	<p>8</p>  <p>11% 7% 15% 1% 1% 2½</p> <p>BOND BEAM 1201072</p>
 <p>11% 7% 15%</p> <p>FLOW THRU BOND BEAM (KNOCK OUT) 1201073</p>	<p>8</p>  <p>1% 11% 7% 11%</p> <p>COLUMN 1201096</p>	<p>*</p>  <p>1% 11% 7% 15%</p> <p>SINGLE CORE 1201097</p>

\* Special Order - Units may be subject to short run charges and minimum order requirements.

8 Full 8" high available.

Bull Nose = 1" Radius.



**MASTERBLOCK**

# 12" BLOCK

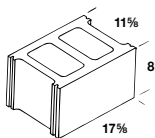

FULL HIGH PLAIN  
1281800

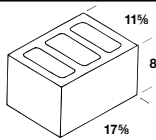

FULL HIGH DOUBLE END  
1281802

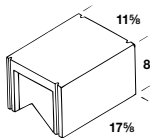

FULL HIGH FILLED TOP  
1281825

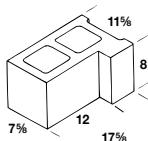

FULL HIGH L-CORNER  
1281803

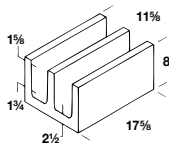

FULL HIGH BOND BEAM  
1281872

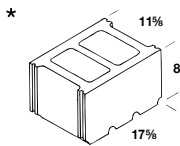

FULL HIGH DRAIN BLOCK  
1281111

# 14" BLOCK

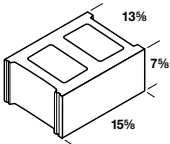

PLAIN  
1401000

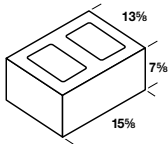

DOUBLE END  
1401002

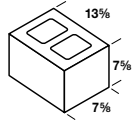

HALF LENGTH  
1401005

\*

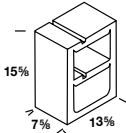

HIGH LINTEL  
(KNOCK OUT)  
1401064

\*

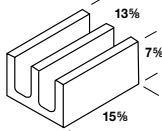

BOND BEAM  
1401072

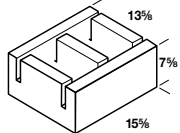

FLOW THRU BOND BEAM  
(KNOCK OUT)  
1401073

\* Special Order - Units may be subject to short run charges and minimum order requirements.



**MASTERBLOCK**

# 16" BLOCK

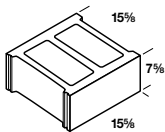

PLAIN  
1601000

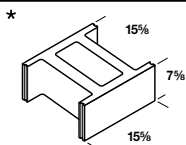

OPEN CORE  
1601001

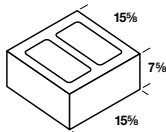

DOUBLE END  
1601002

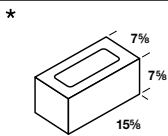

HALF LENGTH  
1601005

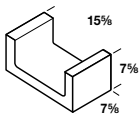

HALF LINTEL  
1601061

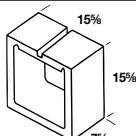

HIGH LINTEL  
(KNOCK OUT)  
1601064

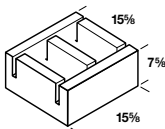

FLOW THRU BOND BEAM  
(KNOCK OUT)  
1601073

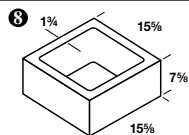

COLUMN  
(12 1/8" SQ. OPENING)  
1601096

\* Special Order - Units may be subject to short run charges and minimum order requirements.

8 Full 8" high available.

# SCORED BLOCK

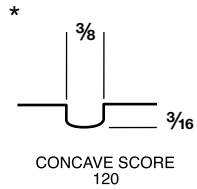
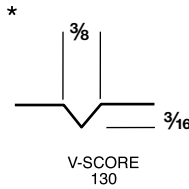
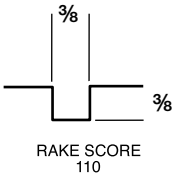

UNITS CAN BE PRODUCED WITH 1, 2, 3 OR 5 VERTICAL SCORES.

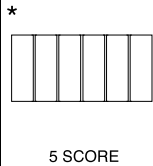
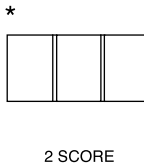
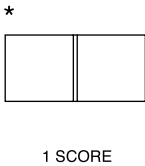

BELOW ARE STOCKED RAKED SCORED BLOCK

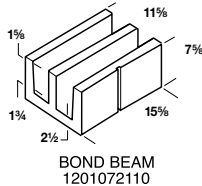
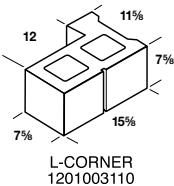
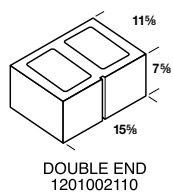
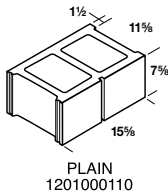
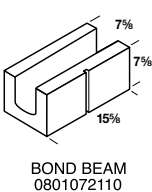
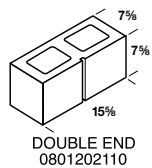
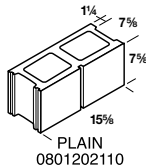
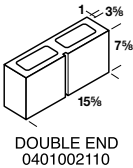

\* Special Order - Units may be subject to short run charges and minimum order requirements.

# SOUNDBLOX®

## SOUND ABSORPTION COEFFICIENTS - TYPE RSC/RF and RSC

Size	Type	Surface	Exposed Slots/ Cavities	Frequency - Hertz																NRC	
				125	160	200	250	315	400	500	630	800	1000	1250	1600	2000	2500	3150	4000		5000
8"	RSC/RF	PAINTED	2/5	.18	.22	.36	.64	1.12	1.16	1.02	.89	.76	.72	.76	.77	.80	.73	.68	.58	.65	.80
10"	RSC/RF	PAINTED	2/5	.18	.22	.36	.64	1.12	1.16	1.02	.89	.76	.72	.76	.77	.80	.73	.68	.58	.65	.80
12"	RSC/RF	PAINTED	2/5	.48	.70	.93	1.14	1.05	.97	.91	.84	.75	.76	.77	.70	.67	.68	.56	.51	.59	.85
12"	RSC/RF-4	PAINTED	2/5	.18	.22	.36	.64	1.12	1.16	1.02	.89	.76	.72	.76	.77	.80	.73	.68	.58	.65	.80
4"	RSC	PAINTED	2/3	.18	.22	.36	.64	1.12	1.16	1.02	.89	.76	.72	.76	.77	.80	.73	.68	.58	.65	.80
6"	RSC	PAINTED	2/3	.48	.70	.93	1.14	1.05	.97	.91	.84	.75	.76	.77	.70	.67	.68	.56	.51	.59	.85
8"	RSC	PAINTED	2/4	.48	.85	1.17	.99	.90	.88	.98	.79	.62	.58	.60	.61	.70	.69	.70	.64	.51	.80
12"	RSC	PAINTED	2/4	.57	*	*	.76	*	*	1.09	*	*	.94	*	*	.54	*	*	.59	*	.85

The above sound absorption data was determined by tests conducted at Geiger and Hamme Acoustical Laboratory in strict compliance with ASTM C423 specifications. Actual installed performance may vary.  
\* Measurements at these frequencies were not taken.

\*



TYPE RSC (4")  
0401507

\*



TYPE RSC (6")  
0601507

\*



TYPE RSC (8")  
0801507

\*



TYPE RSC (12")  
1201507

\*



TYPE RSC/RF (8")  
0801508

\*



TYPE RSC/RF (10")  
1001508

\*



TYPE RSC/RF (12")  
1201508

\*



TYPE RSC/RF 4 (12")  
1201509

\*



TYPE A-1 (4")  
0401501

\*



TYPE A-1 (6")  
0601501

\*



TYPE A-1 (8")  
0801501

\*



TYPE Q (8" ONLY)  
0801502

\*



TYPE RSR (8" ONLY)  
0801505

### NOTE:

All Type RSC/RF, large cavities are straight through.

\* Special Order - Units may be subject to short run charges and minimum order requirements.



**MASTERBLOCK**

# ROCK FACE

\*Scored Rock Face are available on a special order basis.

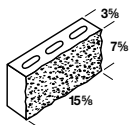

DOUBLE END  
0401002085

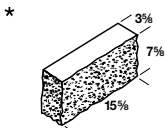

FACE & END CORNER  
0401413085

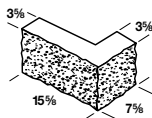

L-CORNER  
0401403085

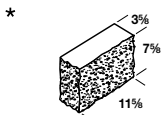

3/4 LENGTH  
FACE & END CORNER  
0401477085

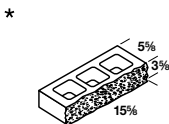

DOUBLE END HALF HIGH  
0641002085

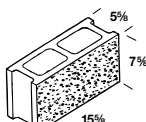

PLAIN  
0601224085

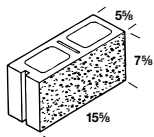

DOUBLE END W/SASH  
0601224085

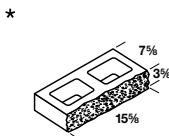

HALF HIGH DOUBLE END  
0841002085

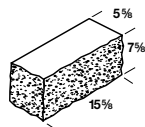

FACE & END CORNER  
0601413085

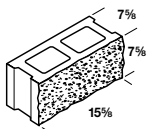

PLAIN  
0801224085

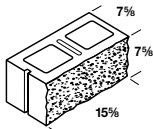

DOUBLE END W/SASH  
0801224085

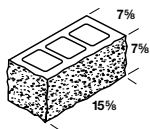

FACE & END CORNER  
0801013085

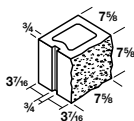

HALF SASH  
0801004085

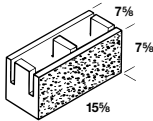

FLOW THRU  
(KNOCK OUT)  
0801073085

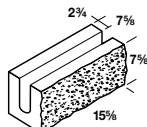

BOND BEAM  
0801072085

\* Special Order - Units may be subject to short run charges and minimum order requirements.

# ROCK FACE



\*Scored Rock Face are available on a special order basis.

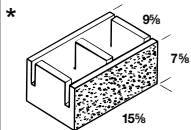

FLOW THRU  
BOND BEAM  
1001073085

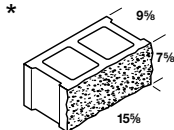

PLAIN  
1001000085

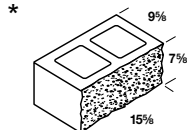

DOUBLE END  
1001002085

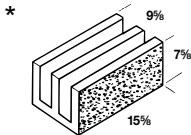

BOND BEAM  
1001072085

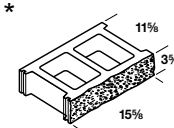

HALF HIGH PLAIN  
1241224085

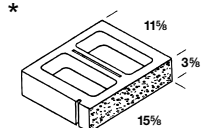

HALF HIGH DOUBLE END  
1241224085

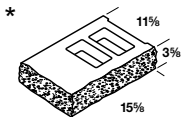

HALF HIGH FACE & END  
CORNER  
1241013085

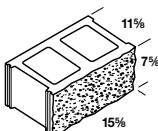

PLAIN  
1201000085

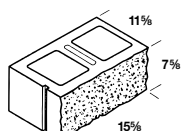

DOUBLE END W/SASH  
1201024085

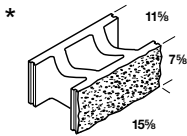

ENERBLOCK  
1201121085

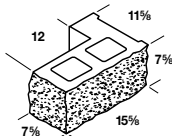

L-CORNER  
1201003085

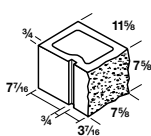

HALF SASH  
1201004085

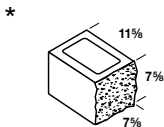

HALF LENGTH  
1201005085

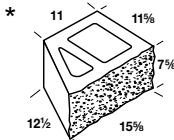

22 1/2° MITERED  
1201048085

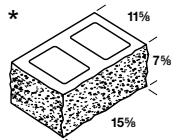

FACE & END CORNER  
1201013085

\* Special Order - Units may be subject to short run charges and minimum order requirements.



**MASTERBLOCK**

# ROCK FACE

\*Scored Rock Face are available on a special order basis.

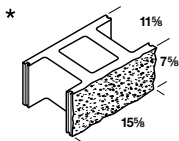

OPEN CORE  
1201001085

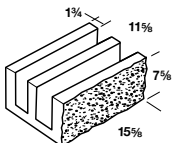

BOND BEAM  
1201072085

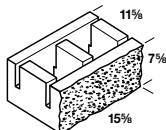

FLOW THRU BOND BEAM  
(KNOCK-OUT)  
1201073085

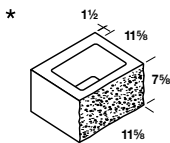

COLUMN  
1201096085

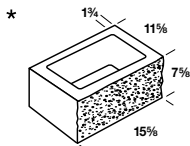

SINGLE CORE  
1201097085

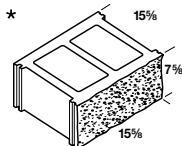

PLAIN  
1601000085

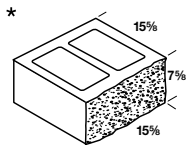

DOUBLE END  
1601002085

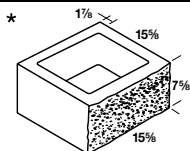

COLUMN  
1601096085

\* Special Order - Units may be subject to short run charges and minimum order requirements.

# SPLYT STONE QUARRY SERIES

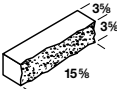
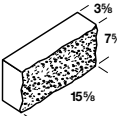
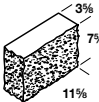
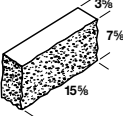
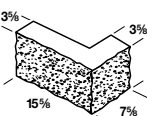
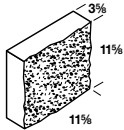
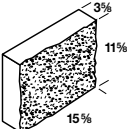
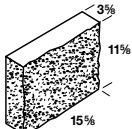
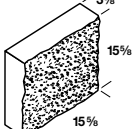
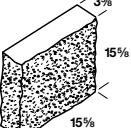
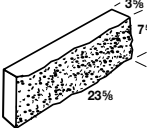
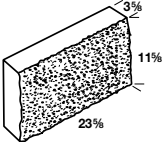
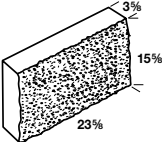

<p>* </p> <p>SOLID VENEER 0441402085</p>	<p>* </p> <p>SOLID VENEER 0401402085</p>	<p>* </p> <p>3/4 LENGTH FACE &amp; END CORNER 0401477085</p>
<p>* </p> <p>FACE &amp; END CORNER 0401413085</p>	<p>* </p> <p>L-CORNER 0401403085</p>	<p>* </p> <p>SOLID VENEER 1241476088</p>
<p>* </p> <p>SOLID VENEER 1241402088</p>	<p>* </p> <p>SOLID VENEER CORNER 1241413088</p>	<p>* </p> <p>SOLID VENEER 1641402088</p>
<p>* </p> <p>SOLID VENEER CORNER 1641413088</p>	<p>* </p> <p>SOLID VENEER 0401441085</p>	<p>* </p> <p>SOLID VENEER 1241441088</p>
<p>* </p> <p>SOLID VENEER 1641441088</p>		

\* Special Order - Units may be subject to short run charges and minimum order requirements.

Note: **FOR SPLYT STONE QUARRY SERIES ASHLAR PATTERNS SEE PAGES 46 AND 47.**



**MASTERBLOCK**

# CASTLE ROCK

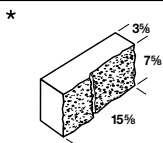
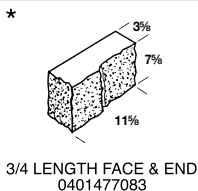
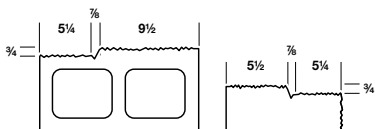

**DOUBLE END**  
0401402083

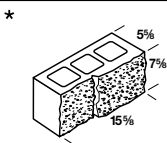

**DOUBLE END**  
0601002083

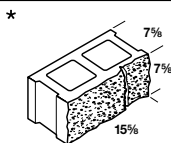

**PLAIN**  
0801224083

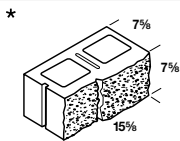

**DOUBLE END W/SASH**  
0801224083

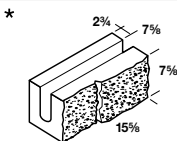

**BOND BEAM**  
0801072083

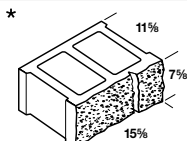

**PLAIN**  
1201224083

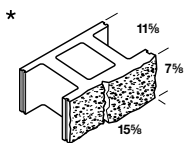

**OPEN CORE**  
1201001083

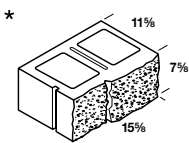

**DOUBLE END W/SASH**  
1201224083

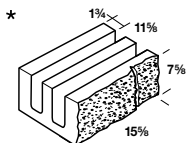

**BOND BEAM**  
1201072083

**\*** Special Order - Units may be subject to short run charges and minimum order requirements.

# CASTLE ROCK CORNER DETAIL



## 4" WALL

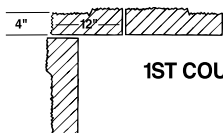

1ST COURSE

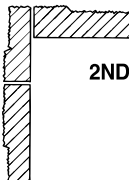

2ND COURSE

## 8" WALL

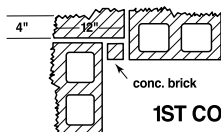

1ST COURSE

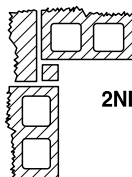

2ND COURSE

## 12" WALL

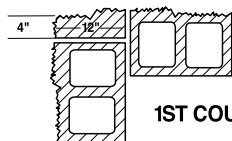

1ST COURSE

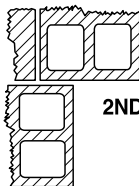

2ND COURSE



**MASTERBLOCK**

# SHADOW STONE

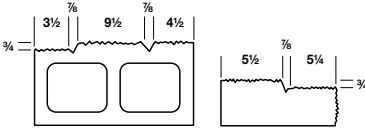

\*

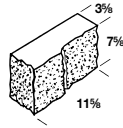

3/4 LENGTH FACE & END  
0401477083

\*

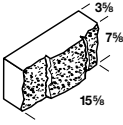

DOUBLE END  
0401402082

\*

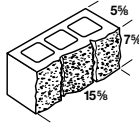

DOUBLE END  
0601002082

\*

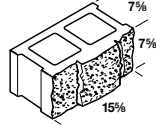

PLAIN  
0801224082

\*

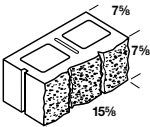

DOUBLE END W/SASH  
0801224082

\*

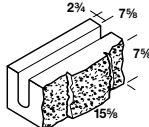

BOND BEAM  
0801072082

\*

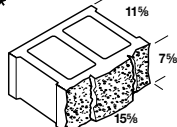

PLAIN  
1201224082

\*

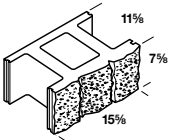

OPEN CORE  
1201001082

\*

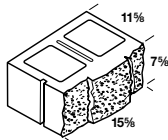

DOUBLE END W/SASH  
1201224082

\*

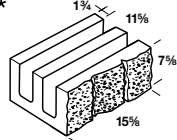

BOND BEAM  
1201072082

\* Special Order - Units may be subject to short run charges and minimum order requirements.

# SHADOW STONE CORNER DETAIL



## 4" WALL

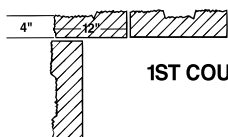

1ST COURSE

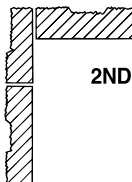

2ND COURSE

## 8" WALL

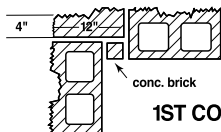

1ST COURSE

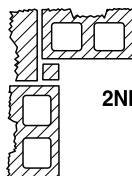

2ND COURSE

## 12" WALL

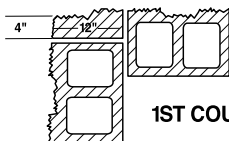

1ST COURSE

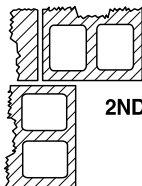

2ND COURSE



MASTERBLOCK

# SPLIT FACE

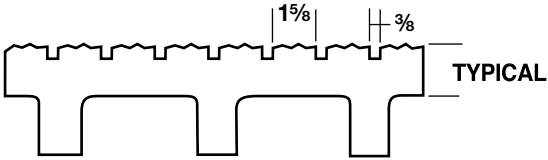

\*

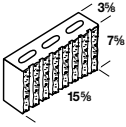

DOUBLE END  
0401002081

\*

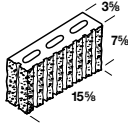

FACE & END CORNER  
0401013081

\*

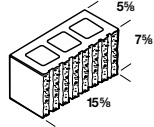

DOUBLE END  
0601002081

\*

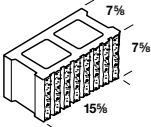

PLAIN  
0801224081

\*

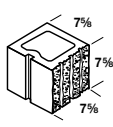

HALF LENGTH W/SASH  
0801004081

\*

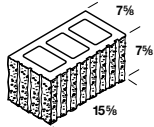

FACE & END CORNER  
0801013081

\*

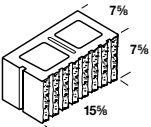

DOUBLE END W/SASH  
0801224081

\*

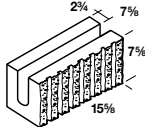

BOND BEAM  
0801072081

\*

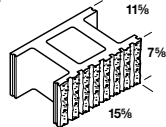

OPEN CORE  
1201001081

\*

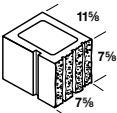

HALF LENGTH W/SASH  
1201004081

\*

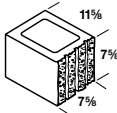

HALF LENGTH  
1201005081

\*

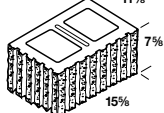

FACE & END CORNER  
1201013081

\* Special Order - Units may be subject to short run charges and minimum order requirements.

# SPLIT FACE

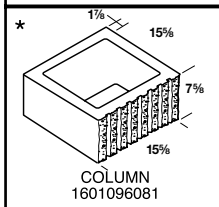
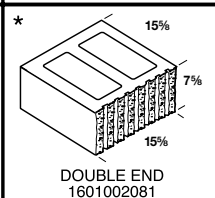
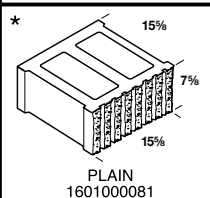
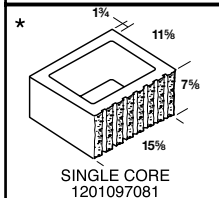
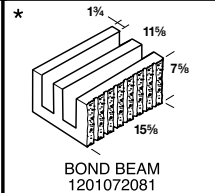
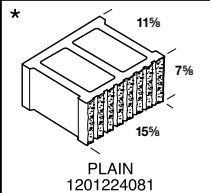
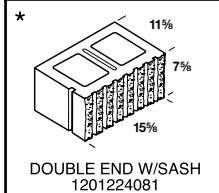

\* Special Order - Units may be subject to short run charges and minimum order requirements.

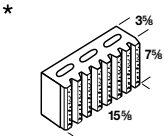
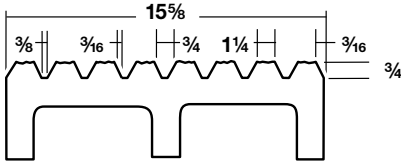

**DOUBLE END**  
0401002066

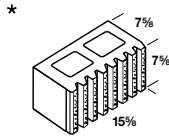

**DOUBLE END**  
0801002066

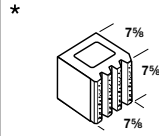

**HALF LENGTH**  
0801005066

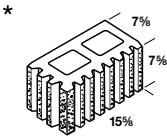

**FACE & END CORNER**  
0801013066

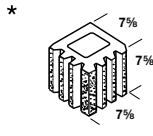

**HALF FACE & END CORNER**  
0801085066

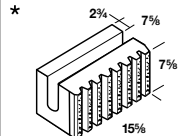

**BOND BEAM**  
0801072066

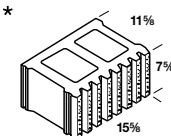

**PLAIN**  
1201202066

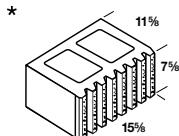

**DOUBLE END**  
1201202066

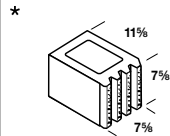

**HALF LENGTH**  
1201005066

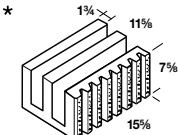

**BOND BEAM**  
1201072066

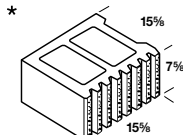

**SINGLE END**  
1601020066

★ Special Order - Units may be subject to short run charges and minimum order requirements.

# BREAK-OFF

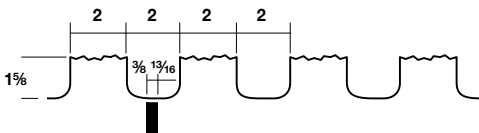

TYPICAL JOINT DETAIL

\*

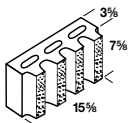

DOUBLE END  
0401002062

\*

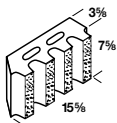

SINGLE MITERED CORNER  
0401046062

\*

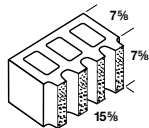

DOUBLE END  
0801002062

\*

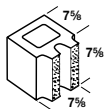

HALF LENGTH  
0801005062

\*

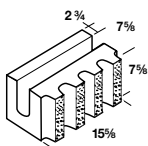

BOND BEAM  
0801072062

\*

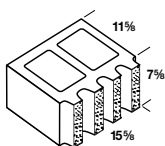

DOUBLE END  
1201002062

\*

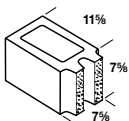

HALF LENGTH  
1201005062

**Note:**  $\frac{3}{16}$ " radius/depth -  $\frac{3}{16}$ " width radius-  $\frac{3}{16}$ " to go from flat to flat.

\* Special Order - Units may be subject to short run charges and minimum order requirements.

# COLOR CHART

#177 GRAY BALSAM (Custom Series)	#128 ASHLAR GRAY (Custom Series)	#100 NATURAL GRAY (Standard Series)	#202 POLAR WHITE (Premier Series)	#218 FRENCH WHITE (Premier Series)	#328 ANTIQUÉ IVORY (Custom Series)	#508 ALMOND (Custom Series)
#395 KASOTA (Premier Series)	#368 COLONIAL IVORY (Custom Series)	#602 GOLDSTONE (Custom Series)	#548 SPICE (Custom Series)	#516 MESA TAN (Custom Series)	#566 AZTEC CLAY (Custom Series)	#872 TERRA COTTA (Custom Series)
#838 ROSEGLOW (Custom Series)	#854 EBONY ROSE (Custom Series)	#889 ROSEWOOD (Custom Series)	#822 SPANISH ROSE (Custom Series)	#622 MAHOGANY (Custom Series)	#638 BARKWOOD (Custom Series)	#616 VIENNA BROWN (Custom Series)

## COLOR CHART

Colors shown above may vary slightly from actual products.  
Contact your local representative for current samples.